

# Cinema Mid-High Loudspeaker System

**QSC**

## User Manual

---

MH-1060X 10" (254 mm) mid, 2.4" (60 mm) compression driver

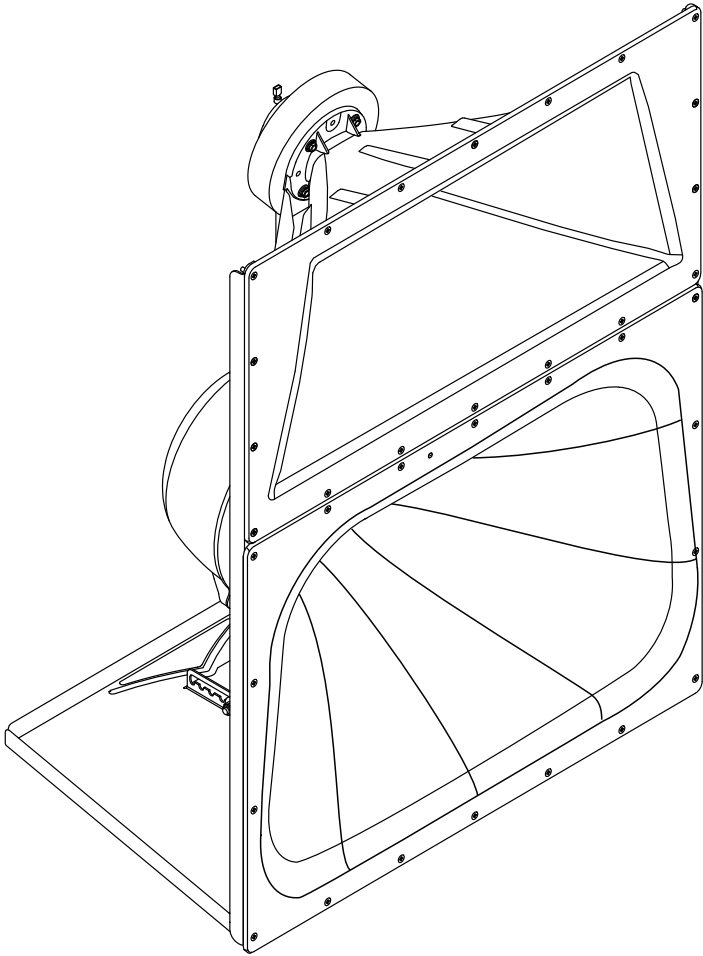

TD-001607-01-A



## EXPLANATION OF SYMBOLS

The term “WARNING!” indicates instructions regarding personal safety. If the instructions are not followed the result may be bodily injury or death.

The term “CAUTION!” indicates instructions regarding possible damage to physical equipment. If these instructions are not followed, it may result in damage to the equipment that may not be covered under the warranty.

The term “IMPORTANT!” indicates instructions or information that are vital to the successful completion of the procedure.

The term “NOTE” indicates additional useful information.



**NOTE:** The lightning flash with arrowhead symbol in a triangle is to alert the user to the presence of un-insulated “dangerous” voltage within the product’s enclosure that may be of sufficient magnitude to constitute a risk of electric shock to humans.



**NOTE:** The exclamation point within an equilateral triangle is to alert the user to the presence of important safety, and operating and maintenance instructions in this manual.



### IMPORTANT SAFETY INSTRUCTIONS



1. Read these instructions and keep a copy for future use.
2. Heed all warnings and follow all instructions.
3. Do not use this loudspeaker in or near water.
4. Do not use any aerosol spray, cleaner, disinfectant or fumigant on, near or into the loudspeaker. Clean it only with a dry cloth.
5. Do not block any openings and keep them free of dust or other matter. Install in accordance with the manufacturer’s instructions.
6. Do not install near any heat sources such as radiators, heat registers, stoves, or other apparatus (including amplifiers) that produce heat.
7. Use caution with any attachments/accessories that are not specified by the manufacturer.
8. Refer all servicing to qualified service personnel. Servicing is required when the loudspeaker has been damaged in any way, such as liquid spilling or objects falling into the loudspeaker; it has been exposed to rain or moisture; it does not operate normally; or it has been dropped.
9. Adhere to all applicable local codes.
10. Consult a licensed professional engineer when any doubt or questions arise regarding a physical equipment installation.

## Maintenance and Repair



**WARNING!:** Advanced technology, including the use of modern materials and powerful electronics, requires specially adapted maintenance and repair methods. To prevent unnecessary damage to the loudspeaker, injuries to persons, and/or the creation of additional safety hazards, all maintenance or repair work on the loudspeaker should be performed only by a QSC authorized service station or an authorized QSC international distributor. QSC is not responsible for any injury, harm or related damages arising from any failure of the customer, owner, or user to facilitate those repairs.

## Introduction

The MH-1060X “mid-high pack” provides the mid and high frequency components of three-way screen channel loudspeaker systems for high performance cinema applications. They were designed to operate with and be directly mounted on QSC’s cinema low-frequency enclosures.

Mid frequencies are reproduced with a 10” (254 mm) high-efficiency, phase-ring loaded driver mounted on a custom designed cinema horn. The high-frequency driver is a large format, 2.4” (60 mm) titanium diaphragm compression driver mounted on a custom high-frequency cinema horn. The high frequency horn is a low-distortion waveguide that provides highly articulate dialogue without coloration associated with conventional horn loudspeakers. Both horns feature broad horizontal and vertical coverage angles to ensure coverage of every seat in the auditorium. The driver assemblies are mounted on an adjustable pan and tilt bracket that has an integral aiming sight to simplify installation.

The MH-1060X loudspeaker includes a passive crossover network with a 2400 Hz crossover between mid- and high-frequency drivers.

Operating in bi-amp mode requires outboard processing to produce the low-frequency and mid-high-frequency bands, as well as two channels of amplification for them.

Operating in passive mode adds a 570 Hz crossover point between the LF and MF drivers. Together with a QSC low-frequency enclosure, this creates a three-way loudspeaker system that operates from a full-range amplifier channel output.

The MH-1060X components come pre-assembled to reduce field assembly time. Only three bolts are required to secure the mid-high assembly to the top of a QSC low-frequency enclosure.



**NOTE:** Install in accordance with QSC’s instructions and with the assistance of a licensed professional engineer. Only use attachments, mounts, accessories, or brackets specified or approved by QSC, LLC. Refer all servicing to qualified personnel. Service is required if the loudspeaker has been damaged in any way.



**WARNING!** Before placing, installing, rigging, or suspending any loudspeaker product, inspect all hardware, suspension, cabinets, transducers, brackets and associated equipment for damage. Any missing, corroded, deformed or non-load rated component could significantly reduce the strength of the installation, placement, or array. Any such condition severely reduces the safety of the installation and should be immediately corrected. Use only hardware that is rated for the loading conditions of the installation and any possible short-term unexpected overloading. Never exceed the rating of the hardware or equipment. Consult a licensed professional engineer when any doubt or questions arise regarding a physical equipment installation.

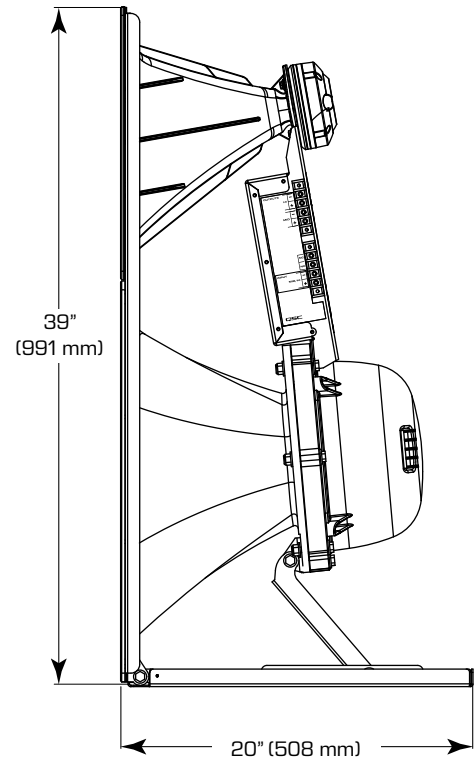
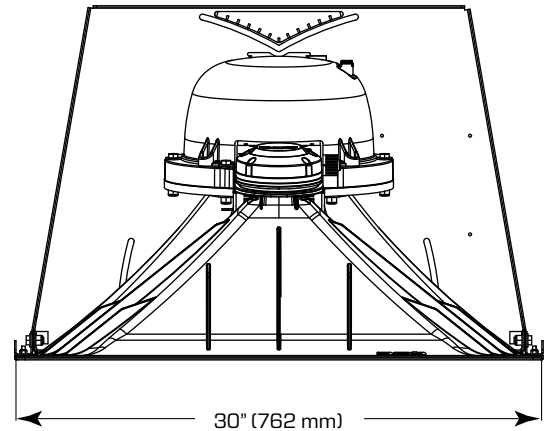

— Figure 1 —

# Mounting

## Attaching to Low Frequency Enclosure

The mid-high loudspeaker assembly attaches to the top of the QSC low frequency cabinet with three 20-mm-long M8 bolts with lock washers (this hardware is factory installed on the low frequency enclosure). Apply medium-strength threadlocking compound to the bolt threads and attach the mid-high loudspeaker assembly loosely at first so you can aim it properly (see the next section). Once the system is properly aimed, tighten the fasteners.

## Aiming

Aim the horn in the horizontal plane (pan) before tightening the attachment hardware. Adjust the vertical tilt with the mid-high vertical adjustment bracket. The mid-high assembly features an aiming sight to help you optimize coverage quickly and easily. For typical applications, the aim point should be the center seat in the back row of the auditorium. If the cinema screen has already been installed, set a flashlight at the desired aim point; in a darkened auditorium it is easily visible through the screen perforations.

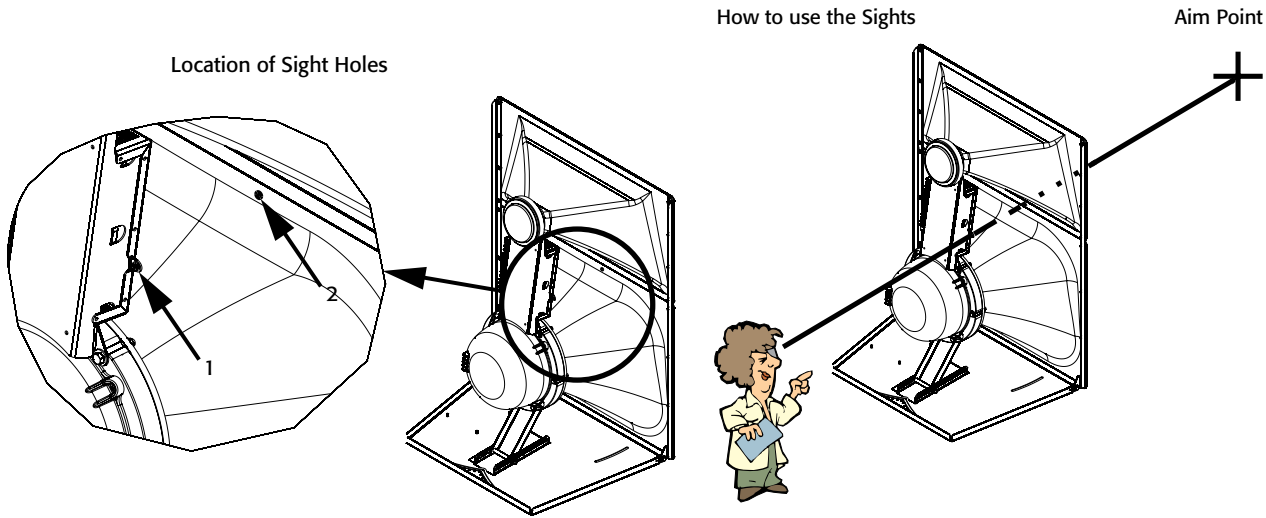

— Figure 2 —

— Figure 3 —

## Bi-Amp Mode Connections



**CAUTION!** Do not connect amplifiers directly to the driver inputs! Always use the input terminal strip.

Figure 4 depicts the bi-amp mode connections for the MH-1060X and its companion low-frequency enclosure.

## Mode Switch

To set up the loudspeaker system for bi-amp mode, set the mode switch to **BI-AMP MODE**. To avoid damaging the loudspeaker system or amplifier, always make sure the mode switch is in the proper position and the loudspeaker is wired correctly before operating the system.

## Input Terminals

The MH-1060X has barrier strip screw terminals that accept up to 6 mm<sup>2</sup> or #10 AWG stranded loudspeaker wire. Observe proper polarity and use the largest wire gauge and shortest length that is practical for the application.

Bi-amp mode requires the use of outboard processing to split the spectrum of the audio channel into the low-frequency band and the mid-high band, then amplifying the two bands separately. Connect the output of the mid-high amplifier channel to the pair of **MID/HI INPUT** terminals. The passive crossover network will properly divide the audio spectrum between the mid- and high-frequency loudspeaker drivers.

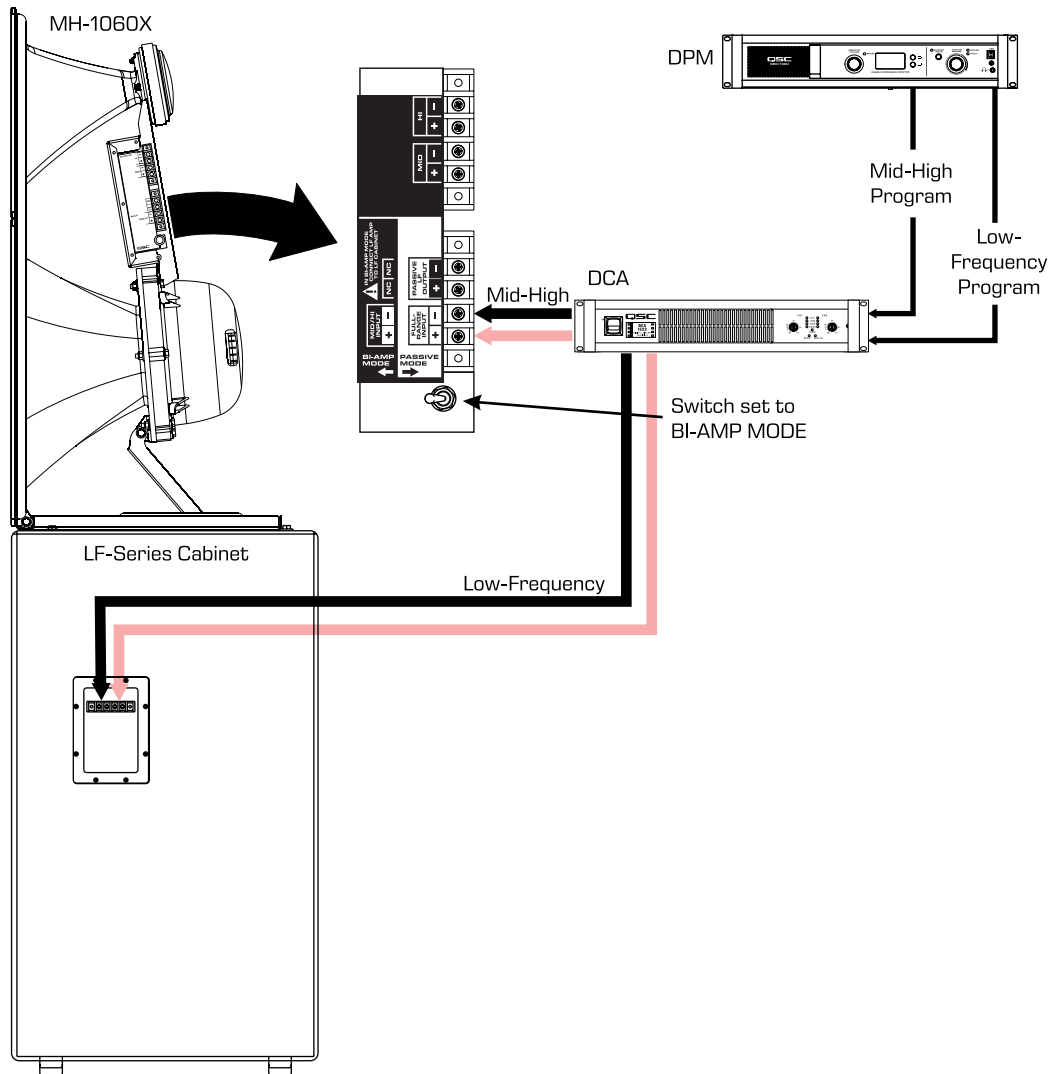

– Figure 4 –

Do not apply signal with low-frequency content below 200 Hz to the mid/hi input.

## Low-Frequency Connection

Connect the low-frequency amplifier channel output directly to the input terminals of the low-frequency enclosure. Do not connect the amplifier channel or the low-frequency enclosure to the terminals on the mid-high assembly.

## Output Terminals

The upper terminals labeled **MID** and **HI** are factory-connected to the drivers, so do not connect anything to them for normal operation.

The **PASSIVE LF OUTPUT** terminals are not used in bi-amp mode.



**NOTE:** Maintain correct polarity at every connection throughout the entire system for optimum performance. Do not connect any signal to the **MID** and **HI** terminals.

# Passive Mode Connections



**CAUTION!:** Do not connect amplifiers directly to the driver inputs! Always use the input terminal strip.

Figure 5 depicts the passive mode connections for the MH-1060X and its companion low-frequency enclosure.

## Mode Switch

To set up the loudspeaker system for passive mode, set the mode switch to **PASSIVE MODE**. To avoid damaging the loudspeaker system or amplifier, always make sure the mode switch is in the proper position and the loudspeaker is wired correctly before operating the system.

## Input Terminals

The MH-1060X has barrier strip screw terminals that accept up to 6 mm<sup>2</sup> or #10 AWG stranded loudspeaker wire. Observe proper polarity and use the largest wire gauge and shortest length that is practical for the application.

In passive-mode operation, apply full-range audio from the amplifier output to the pair of **FULL RANGE INPUT** terminals. The passive crossover will properly divide the audio spectrum among the loudspeaker drivers.

## Output Terminals

The upper terminals labeled **MID** and **HI** are factory-connected to the drivers, so do not connect anything to them for normal operation.

The pair of terminals labeled **PASSIVE LF OUTPUT** connect to the **INPUT** terminals of the low-frequency loudspeaker enclosure. Use the wire included or a large-gauge (up to 6 mm<sup>2</sup> or #10 AWG) and reasonably short pair of stranded copper wire to make the connection. This is the output of the passive crossover's low-pass output.



**NOTE:** Maintain correct polarity at every connection throughout the entire system for optimum performance. Do not connect any signal to the **MID** and **HI** terminals.

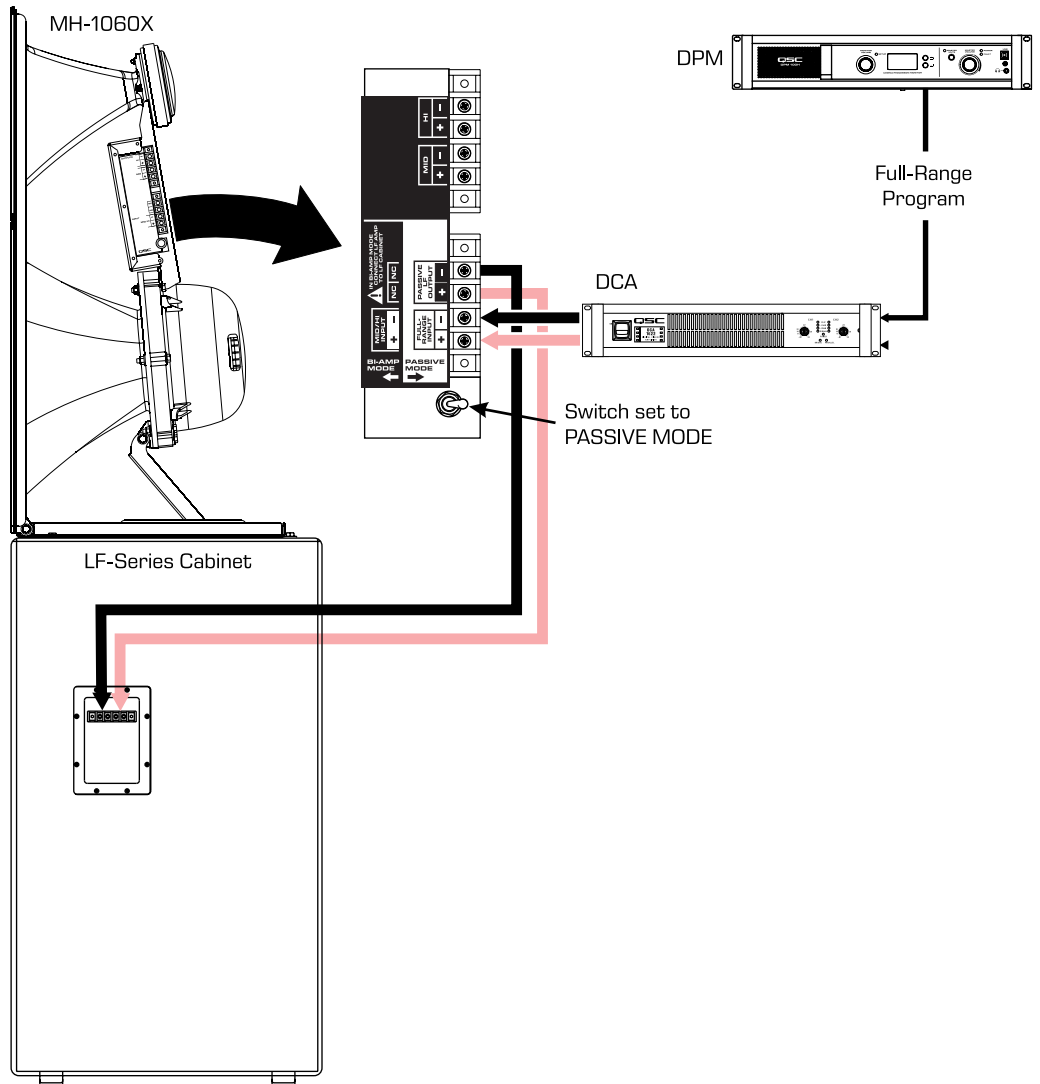

— Figure 5 —



**Mailing Address:**

QSC, LLC  
1675 MacArthur Boulevard  
Costa Mesa, CA 92626-1468 U.S.

**Telephone Numbers:**

Main Number: +1.714.754.6175  
Sales & Marketing: +1.714.957.7100 or toll free (U.S. only) 800.854.4079  
Customer Service: +1.714.957.7150 or toll free (U.S. only) 800.772.2834

**Facsimile Numbers:**

Sales & Marketing FAX: +1.714.754.6174  
Customer Service FAX: +1.714.754.6173

**World Wide Web:**

[www.qsc.com/cinema/](http://www.qsc.com/cinema/)

**E-mail:**

[info@qsc.com](mailto:info@qsc.com)  
[cinematechsupport@qsc.com](mailto:cinematechsupport@qsc.com)

**QSC Self Help Portal**

Access our Self-Help Portal for additional information, FAQs, and documents. You may also register or log in to open a case with QSC Technical Services.

<https://qscprod.force.com/selfhelpportal/s/>