



unD6IO

4x2 Multi-IO Dante®/AES67 Wall Plate



User Manual

Date 2/21/2020

1675 MacArthur Boulevard · Costa Mesa, CA 92626

Ph: 800/854-4079 or 714/957-7100 · Fax: 714/754-6174

© 2020 QSC, LLC all rights reserved. QSC and the QSC logo are registered trademarks of QSC, LLC in the U.S. Patent and Trademark office and other countries. All other trademarks are the property of their respective owners. Patents may apply or be pending.

www.qsc.com

614-00029

IMPORTANT SAFETY INSTRUCTIONS

The symbols below are internationally accepted symbols that warn of potential hazards with electrical products.



This symbol, wherever it appears, alerts you to the presence of un-insulated dangerous voltage inside the enclosure -- voltage that may be sufficient to constitute a risk of shock.



This symbol, wherever it appears, alerts you to important operating and maintenance instructions in the accompanying literature. Please read the manual.

1. Read these instructions.
2. Keep these instructions.
3. Heed all warnings.
4. Follow all instructions.
5. Do not use this apparatus near water.
6. Clean only with a dry cloth.
7. Do not block any ventilation openings. Install in accordance with the manufacturer's instructions.
8. Do not install near any heat sources such as radiators, heat registers, stoves, or other apparatus (including amplifiers) that produce heat.
9. Protect the power cord (Ethernet cable) from being walked on or pinched particularly at plugs, convenience receptacles, and the point where they exit from the apparatus.
10. Only use attachments/accessories specified by Attero Tech
11. Unplug this apparatus during lightning storms.
12. Refer all servicing to qualified service personnel. Servicing is required when the apparatus has been damaged in any way, such as power-supply cord or plug is damaged, liquid has been spilled or objects have fallen into the apparatus, the apparatus has been exposed to rain or moisture, does not operate normally, or has been dropped.
13. If rack mounting, provide adequate ventilation. Equipment may be located above or below this apparatus but some equipment (like large power amplifiers) may cause an unacceptable amount of hum, or may generate too much heat and degrade the performance of this apparatus.



TO REDUCE THE RISK OF FIRE OR ELECTRIC SHOCK, DO NOT EXPOSE THIS APPARATUS TO RAIN OR MOISTURE.

WARRANTY INFORMATION

For a copy of the QSC Limited Warranty, visit the QSC website at www.qsc.com

Note: This equipment has been tested and found to comply with the limits for a Class A digital device, pursuant to Part 15 of the FCC Rules and EN55022. These limits are designed to provide reasonable protection against harmful interference when the equipment is operated in a commercial environment. This equipment generates, uses, and can radiate radio frequency energy and, if not installed and used in accordance with the instruction manual, may cause harmful interference to radio communications. Operation of this equipment in a residential area is likely to cause harmful interference, in which case the user will be required to correct the interference at their own expense



This symbol means the product must not be discarded as household waste, and should be delivered to an appropriate collection facility for recycling. Proper disposal and recycling helps protect natural resources, human health and the environment. For more information on disposal and recycling of this product, contact your local municipality, disposal service, or the business where you bought this product.



Contents

1 - Overview	4
1.1 - What's in the Box	7
1.2 - Optional Extras	7
1.3 - Device Features	8
1.4 - Mounting and Installation	9
1.5 - Error Reporting	10
1.6 - Hardware Connections	10
1.6.1 - Balanced Output to a Balanced Input	10
1.6.2 - Balanced Output to an Unbalanced Input	10
1.7 - Factory Reset	11
2 - Device Configuration	12
2.1 - IP Address Setup	12
2.2 - Software Control	13
2.3 - 3 rd Party Control	13
2.4 - Control Interface Type	13
2.4.1 - Using the Command interface	13
3 - ARCHITECTS & ENGINEERING SPECIFICATION	14
3.1 - unD6IO A&E Specifications	14
3.2 - Device Specifications	1
APPENDIX A - Reference Documents	A-1

1 - Overview

The unD6IO Dante™ Audio interface is 4x2 Dante/AES67 multi-IO wall plate interfaces designed for in-wall installation into 2-gang US junction boxes. Its form-factor and I/O density make it easy to put Dante connectivity close to audio sources used in professional AV installations – thereby eliminating costly and interference prone analog wiring, power supplies and giving a clean, finished look to an AV installation all while providing the superior audio system flexibility with Dante audio networking.



Figure 1 - unD6IO Overview

The unD6IO features two balanced line-level inputs on XLR connectors. Each input features a software controlled mic preamp with software switchable 48V phantom power.

The unD6IO also features two sets of stereo line-level audio connections for consumer audio device connectivity. The RCA inputs (IN 3/4 A) and 3.5mm stereo input (IN 3/4B) are software selectable to be used as two independent stereo inputs (each mono summed), or summed together as shown in the following signal flow diagram.

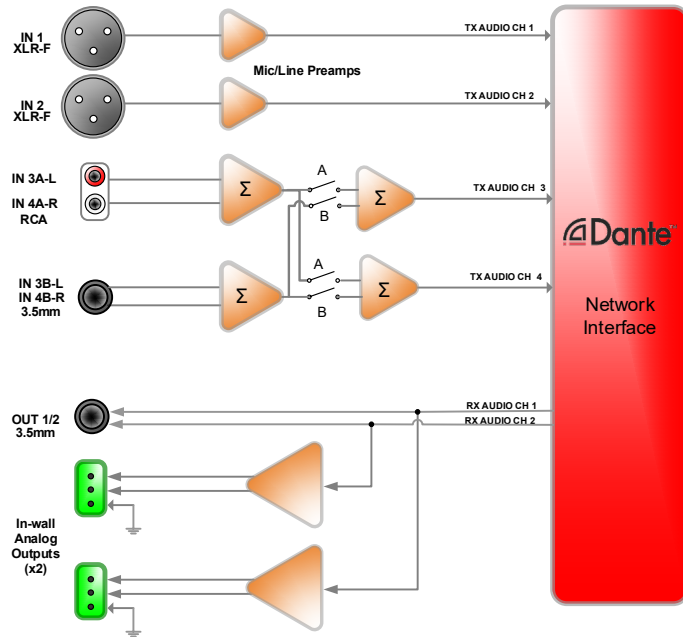

Figure 2 - unD6IO Signal Flow Diagram

All four input paths from both the balanced and unbalanced inputs are digitized and then introduced as discrete channels on the Dante network. In addition to the input functionality, the unD6IO also features two output channels which can be received independently from the Dante network. The outputs are available on the front panel via a 3.5mm stereo jack output connector and also on a 6-way de-pluggable Phoenix style connector on the side of the unit. The Phoenix audio output connections are intended for use with a companion wall plate (*sold separately*) and installed in a 3-gang junction box.

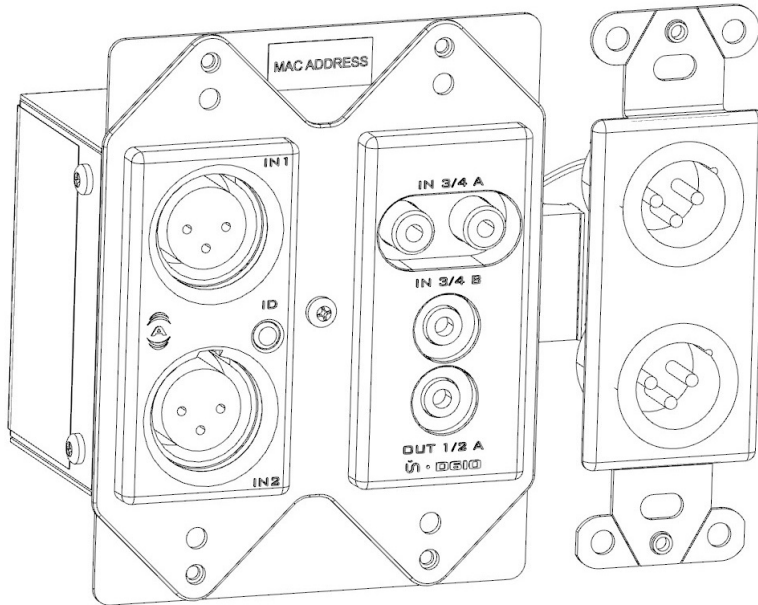

Figure 3 - unD6IO with unXP20 Plate (Front)

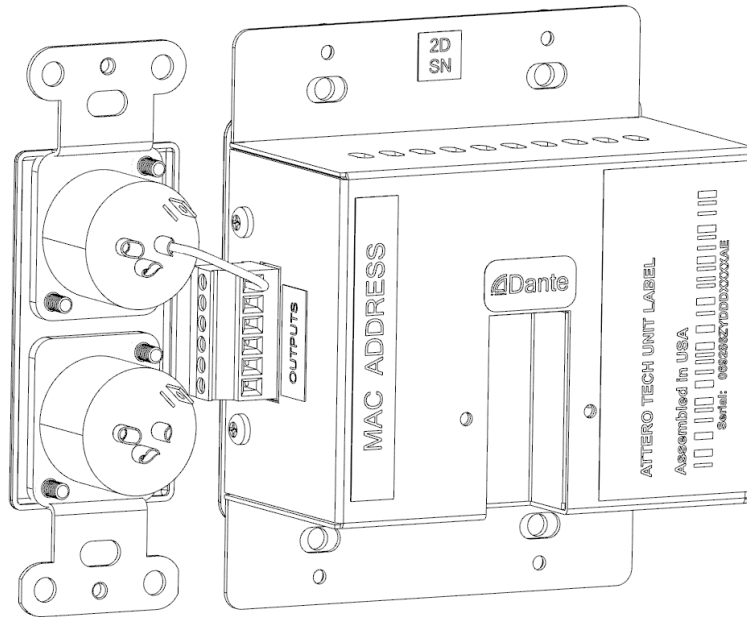

Figure 4 - unD610 with unXP20 Plate (Rear)



Connection to the Dante network is provided by a single Ethernet RJ45 connector on the back of the unit. The unD6IO is PoE-enabled which allows the unD6IO to be powered over its network cable from a suitable PoE source (IEEE 802.3af) eliminating the need for a local power supply. This is particularly useful as the unD6IO can then be mounted in remote location where access to a mains outlet would be limited or indeed, non-existent.

Audinate's Dante Controller or other 3rd party manufacturer's Dante routing software can be used to control the audio routing configuration of the device while the Attero Tech by QSC unIFY Control Panel application (V2.0 or later) or supporting DSP partner software can be used to configure the device-specific features.

The unD6IO also supports third party control systems allowing external configuration of its settings such as phantom power and input gain in real time. Further information on 3rd party control can be found later in this document in section 2.3 – 3rd Party Control.

1.1 – What's in the Box

The device comes supplied with the following:

- (1) unD6IO
- (1) 2-gang Decora cover plate cover w/mounting screws

1.2 – Optional Extras

The following are available as options for the unD6IO and that may be ordered separately:

- unXP2O - Passive Dual XLR Male single gang Decora wall plate - P/N: 900-00187-01
(Comes with 3-gang Decora cover plate).

1.3 – Device Features

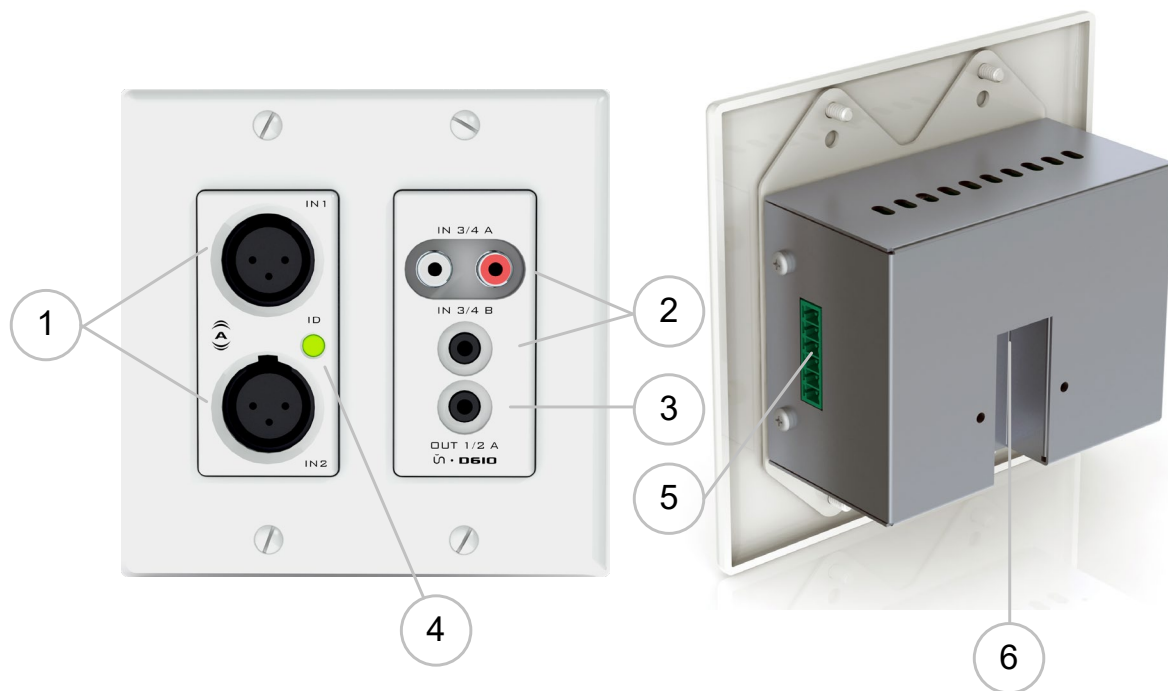

1	XLR Balanced Mic/Line inputs 1/2
2	Stereo unbalanced line level inputs 3/4 A&B (Mono Summed)
3	3.5 mm stereo unbalanced outputs 1/2 A (Mono Summed)
4	Front panel POWER & ID LED status indicator
5	In-wall balanced audio line outputs on de-pluggable Phoenix connectors (Outputs 1/2 B)
6	Recessed RJ-45 connector

***Note:** The unD6IO has a label on the front of the metal housing at the top that shows the device's MAC address. This is important for initial device identification as the last six digits make up part of the device's default network name that is shown when the device is detected by Dante Controller. The full MAC address is also given on the back of the unit.

1.4 – Mounting and Installation

A typical installation will involve mounting the wall plate into a pre mounted 2-gang or larger wall box, standard drywall bracket or mud ring. Before starting, make sure the wall box where the unD6IO is to be installed is pre-wired with a suitable CAT5e or better cable back to a PoE-enabled network switch or mid-span injector. If a mid-span injector is being used, the cable should be connected to the port that supplies both Ethernet and power (refer to the mid-span injectors manual if unsure which port is which). The unD6IO packaging includes all of the necessary screws for mounting the product and the included Decora wall plate.

***Note:** All Attero Tech by QSC products are tested using UTP cabling and it is recommended that UTP cabling be used when installing them. STP cabling can be used for installation though care must be taken not introduce grounding issues into the system by doing so.

Attach the network cable from the switch/mid-span injector to the Dante I/F port of the Dante unD6IO. If the switch or mid-span injector is already running and PoE is enabled, the unit should power up and the green ID LED on the front of the device should turn on.

With the cable attached, carefully place the unD6IO into the wall box taking care to not trap the cabling. Once fully in place, secure it with the screws provided. Once the unit is secured in the wall box, fit the Decora plate over the front of the unit and secure it with the screws provided with it. It is recommended to not over-tighten the screws that attach the included Decora wall plate to prevent cracking it.

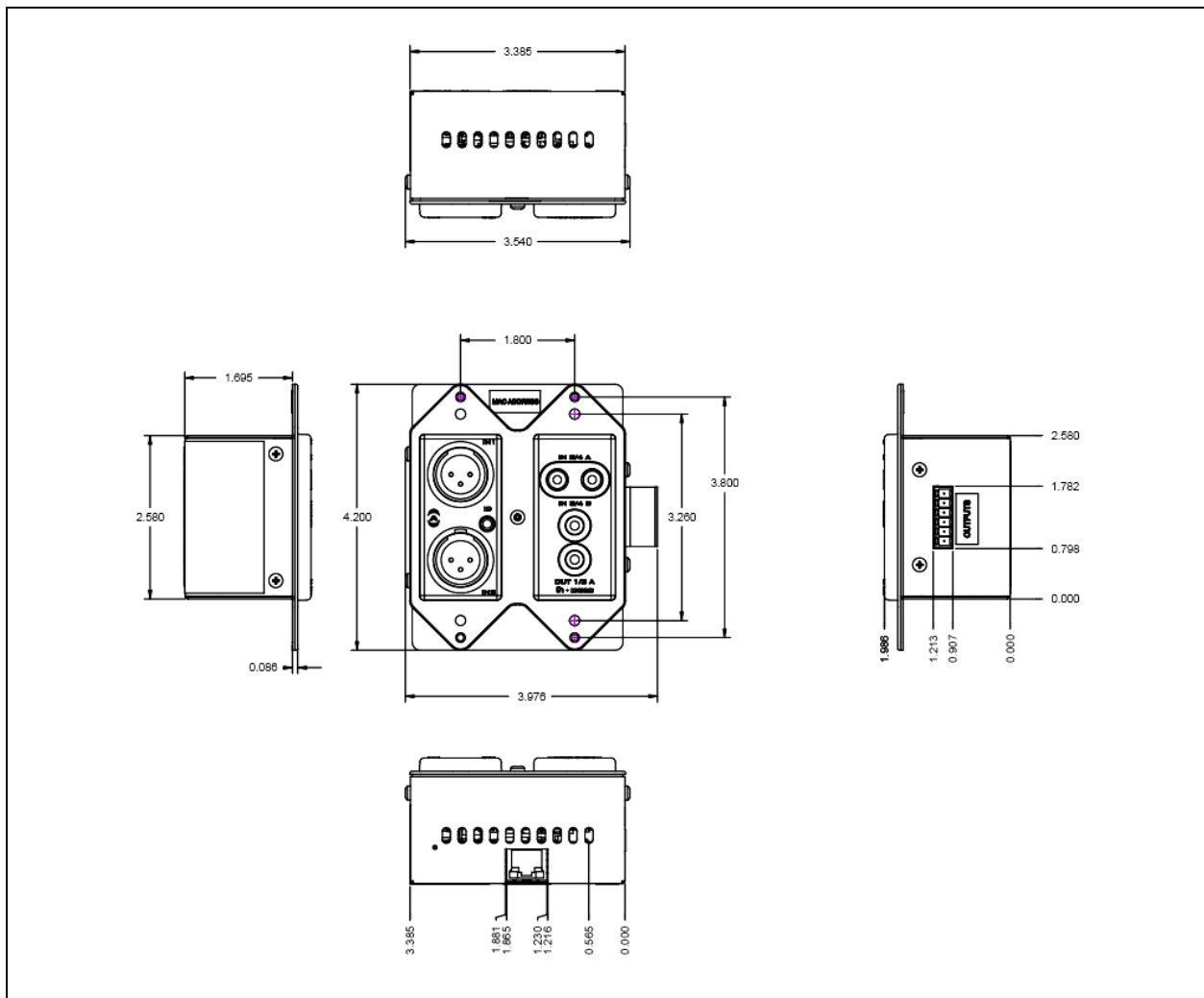

Figure 5 - Dimensioned Drawing

1.5 – Error Reporting

The unD6IO is equipped with error reporting features. Upon power up, the front panel power LED will briefly light red and then change to green if the device boots successfully. If the LED remains on solid red, this indicates a device failure. If power cycling the unit does not correct this problem, contact QSC technical support.

1.6 – Hardware Connections

The unD6IO provides balanced audio outputs to external analog audio equipment. Refer to the following diagrams and instructions for connecting different types of audio devices to the outputs of the unD6IO. Professional grade audio cabling is recommended to achieve the best audio performance throughout the system.

1.6.1 – Balanced Output to a Balanced Input

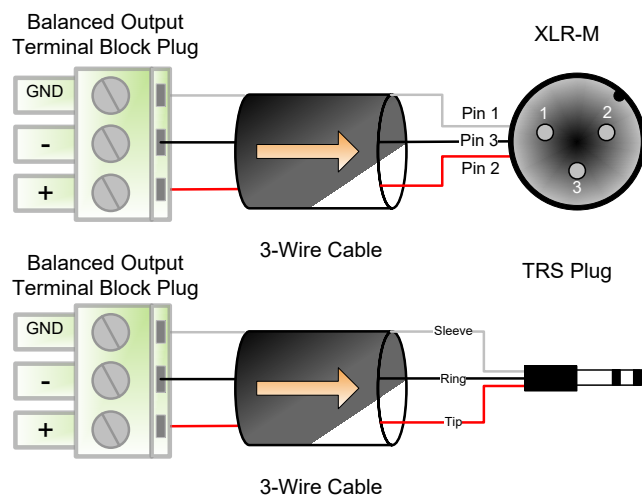

Figure 6 - Balanced Wiring Guide

1.6.2 – Balanced Output to an Unbalanced Input

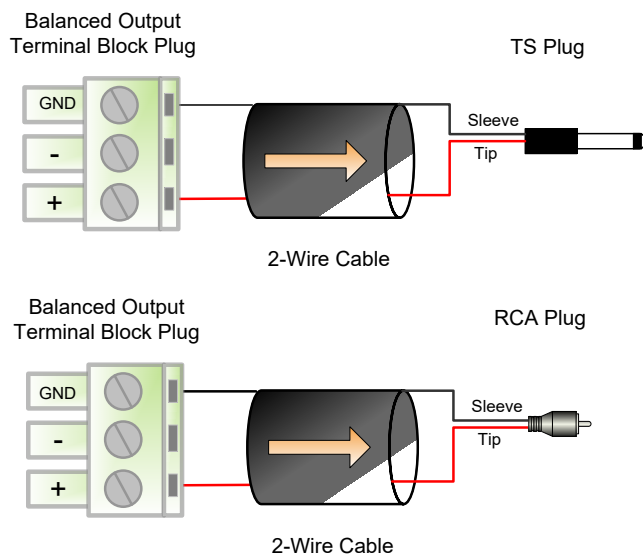
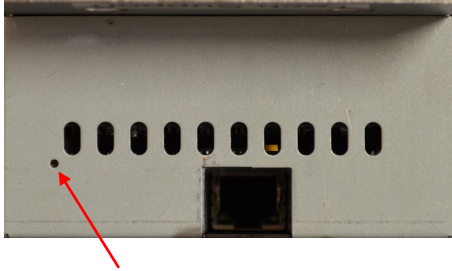

Figure 7 - Unbalanced Wiring Guide

1.7 – Factory Reset

The unD6IO has a factory reset option. Using it will reset all the devices parameters back to their factory defaults including all the Dante settings such as device name, channel names as well as the device settings such as input select. The devices IP address mode is also reset back to getting a dynamic IP.



Access to the factory reset button is through a small circular hole on the underside of the unit, next to the ventilation cutouts.

To use the factory reset, insert a small screwdriver or paperclip into the hole to activate the factory reset switch. There should be a noticeable “click” when it’s activated. Hold the switch in for 5 to 10 seconds then release. If the factory reset was successful, the unit will actually reset indicated by the power LED will turning red.

2 – Device Configuration

Certain 3rd party manufacturers provide audio routing functionality from within their own configuration application. Check the applications manual/help or contact the manufacturer in question to see if this is supported. If not supported by a 3rd party tool, the audio routing may be carried out using Audinate’s Dante Controller. Dante Controller can be obtained from the [Audinate website](#) and is available for both Mac and PC. Instructions on how to use this application and about setting up routes on a Dante network can also be found on Audinate’s website.

**Note: When using Dante controller, the unD6IO will be shown using a default device name of “unD6IO-#####” where ‘#####’ is the last six characters of the devices MAC address.*

Configuration of the unD6IO’s specific features are carried out using the Attero Tech by QSC’s unIFY Control Panel application. This application is available for download on the [QSC website](#). It should be used to configure and modify the device specific features at the time of system installation and commissioning.

2.1 – IP Address Setup

***** IMPORTANT *****

Failure to correctly configure IP addresses will not allow an unD6IO device to correctly authenticate in the unIFY Control Panel software and while it will show up in Dante Controller, the devices parameters will not be available. The input and output channels also won’t be visible and routing of audio to and from the device will not be possible.

In order to configure an unD6IO, both to set up internal parameters and also setup audio routing, the PC/Mac will need to be able to communicate with the devices over the network. While all Dante devices will be discovered regardless of the IP address setup on the PC or Mac, communication can only occur if the PC/Mac and the device have compatible IP addresses.

By default, the unD6IO is set to get a dynamic IP address. As with all Dante devices, if the unD6IO does not find a DHCP server to retrieve an IP address from, it will give itself a local link address sometimes also known as an automatic private IP address (APIPA) instead. A local link IP address is always in the range 169.254.x.y.

To ensure communication, the PC/Mac can either be set to get a dynamic IP address, or be given a static IP address in the range 169.254.x.y. The PC may require a restart if its IP address is changed for the change to take effect.

In some applications, IP addresses of devices may need to be set to something specific and that can be done once initial communication has been established. Bear in mind however that if a static IP address is assigned to a device and that static IP address is in a different range to the IP it was previously using to communicate with the PC/Mac, the PC/Mac will lose communication with the device until such time as the PC/Mac IP address is also changed to an IP in range of the devices new IP address.

Further information on IP setup for an audio system using Dante™ can be found in the FAQ’s on the [Audinate website](#).

2.2 – Software Control and Control

The unD6IO is fully supported in unIFY Control Panel v3.2 and newer software. For a full description of the software and configuration features refer to the integrated help documentation within the unIFY Control Panel application.

2.3 – 3rd Party Control

The unD6IO supports 3rd party control allowing external system to manage the unD6IO's settings such as phantom power, mic/line gain options and control of presets.

2.4 – Control Interface Type

There are two control interface types available. The first type is a Dante™ proprietary interface (-C) which is typically used by devices already that have built-in support for Attero Tech by QSC devices. The second type supports a 3rd party UDP interface (-U) and is available to anyone to use with any device capable of sending and receiving UDP messages.

The type of command interface a specific device supports is defined by the Dante™ firmware it has been loaded with. There are two methods to determine which Dante™ firmware and thus which command interface that is:

- 1) unIFY Control Panel V2.0 or later: Right-clicking on the device in the device list, mouse over the “Device Info” option and then look for the “Control Type” option. A “-C” means the device is using the Dante™ Proprietary interface. A “-U” means the device is using the Direct UDP interface.
- 2) Dante™ Controller™: Double-click on the device in question in the routing grid to display the “Device View” form, select the “Status” tab and look for the “Product Version” and “Firmware Version” parameters in the “Device Information” section.

Product Version	Firmware Version	Control Interface
V4.x.x	V1.0.0	Dante™ Proprietary (-C)
V4.x.x	V2.0.0	Direct UDP (-U)

All Attero Tech by QSC “un” devices ship with the -U control option. However, this control option can be easily changed in the field by updating the device's firmware. Firmware updates can be done within [unIFY Control Panel Software](#) (v2.3 and later). The latest firmware .SFU files can be downloaded from the [Attero Tech Product Firmware](#) page on the QSC website.

2.4.1- API Documentation

Information on the commands the unD6IO supports, as well as details of how to use the 3rd party UDP interface are available for download from [unD6IO product page](#) on the QSC website.

2.4.2 – Using the Command interface

In order to make use of the control interface, regardless of type, the unD6IO and the controlling device need to be on the same physical subnet and need to have IP addresses in the same range. The control devices should then be able to converse with the unD6IO without any further configuration necessary.

3 – ARCHITECTS & ENGINEERING SPECIFICATION

3.1 – unD6IO A&E Specifications

The Dante 2-gang wall plate interface unit shall provide two front panel mounted mic/line analog inputs on XLR. Selectable gains of -18dB, -3dB, +25dB, and +40dB and a +48V phantom power option shall be provided via software for each balanced mic/line input. These mic/line inputs are digitized and introduced to the Dante audio network as transmit channels 1 and 2.

The device shall also provide two sets of unbalanced line level input connections: one on a set of RCA connectors, the other using a stereo 3.5mm TRS connection. The stereo pairs from each input are mono summed and selectable for independent or summed operation via software and introduced to the Dante interface on Dante transmit channels 3 and 4. The internal analog to digital signal conversion shall be performed at 24-bit resolution with a sampling frequency of 48 kHz.

The Dante interface unit shall provide two balanced analog inputs on the side of the in-wall enclosure via a 6-pin depluggable Phoenix-style connector for analog conversion of up to 2 Dante digital audio network channels. Additionally, the two received Dante output channels shall also be converted and output on a front panel mounted 3.5mm stereo TRS connector. The internal digital to analog signal conversion shall be performed at 24-bit resolution with a sampling frequency of 48 kHz.

The Dante interface unit shall receive power over the Ethernet cable from an IEEE 802.3af PoE compliant network switch or midspan injector.

The Dante interface shall be compliant with the RoHS, WEEE and REACH directives. The Dante interface unit shall be Compliant with the EMI/EMC requirements for FCC and CE.

The Dante interface unit shall be the Attero Tech by QSC unD6IO.

3.2 – Device Specifications

Audio Inputs	
Input Types:	Two Balanced and RF filtered inputs on XLR (<i>Inputs 1/2</i>) Stereo Unbalanced Inputs on RCA (<i>Inputs 3/4 A</i>) Stereo Unbalanced Inputs on 3.5mm TRS (<i>Inputs 3/4 B</i>)
Gain:	-18dB, -3dB, +25dB and +40dB, software selectable (<i>Inputs 1/2</i>)
Input Impedance:	>1.8K Ohms at any gain (<i>Inputs 1/2</i>) >10k Ohms (<i>Inputs 3/4 A & B</i>)
Maximum Input Levels:	+20dBu @ -18dB gain, +6dBu @ - 3 dB gain, -23dBu @ +25dB gain -38dBu @ +40dB gain (<i>Inputs 1/2</i>) +12 dBu (<i>Inputs 3/4 A & B</i>)
Phantom Power:	+48V, software selectable (<i>Inputs 1/2 only</i>)
Audio Input Performance	
EIN:	-115 dBu (<i>Mic Inputs 1/2</i>)
THD+N:	< 0.02% @ 1kHz for all gain settings, input signal 3dB below maximum. (<i>Mic Inputs 1/2</i>) <0.01% (<i>Line Inputs 3/4</i>)
Frequency Response:	20Hz - 20kHz, +/- 1dB (<i>-18 and - 3 dB gain on Inputs ½</i>) 50Hz - 20kHz +/- 1dB (<i>+25dB and +40dB gain on Inputs ½</i>) 20Hz - 20kHz, +/- 1dB (<i>Inputs ¾ A & B</i>)

Audio Outputs	
Output Type:	Two balanced line level with automatic muting on loss of Dante signal on 6-pin Depluggable Phoenix (<i>Outputs ½ B</i>) Two unbalanced line level outputs on stereo 3.5mm TRS (<i>Outputs ½ A</i>)
Attenuation Range:	Software controlled volume (<i>0 to -60dB, 1dB increments</i>)
Output Impedance:	200 Ohms balanced, 100 Ohms unbalanced
Maximum Output Levels:	+12 dBu at 0dB attenuation (<i>Output 1/2 A</i>) +20dBu at 0dB attenuation (<i>Output 1/2 B</i>)
Audio Output Performance	
Dynamic Range:	>97 dB
THD+N:	<0.01% @ 1kHz, input signal 3dB below maximum
Frequency Response	20Hz - 20kHz, +/- 1dB (<i>-18dB and - 3dB gain</i>) 50Hz - 20kHz +/- 1dB (<i>+25 and +40 dB gain</i>)



Attero Tech by QSC unD6IO User Manual

Dante Network	
Physical Level:	Standard Ethernet
Connector:	Single RJ-45
Cable Quality:	CAT-5e or better
Transmission Speed:	100 Mbps
Supported Sample Rates	44.1kHz 48kHz
Minimum Dante Network Latency	1ms
Power Requirements	
PoE	802.3af PoE PD compliant
Power Consumption	5.5W Max
Cable Quality:	CAT-5e or better

Physical Dimensions	
Width	3.54"
Height	4.2"
Depth	2"
Weight	0.6 lbs.
Product Compliance	
FCC CFR 47 Parts 15B Class A ICES-003 CE (EN55022) RoHS REACH	



APPENDIX A – Reference Documents

The following table lists the relevant reference documents.

Document Title	Location
unIFY 3 rd Party Software API	QSC website
Dante Firmware Update Quick Start	QSC website

Document Information

Document title:	unD6IO
Document file name:	unD6IO User manual.docx
Revision number:	<02_b>
Issued by:	Attero Tech by QSC
Issue Date:	10/16/2017
Status:	Released

Revision History

Revision	Date	Author	Description of change
01_a	3/11/2016	JDA	Initial Draft
01_b	5/13/2016	JDA	Revisions from first review.
01_c	5/13/2016	CNL	Changes after Review
02	05/13/16	CNL	Release Version 02
02_a	07/17/17	CNL	Added Factory reset function information
02_b	10/16/17	CNL	Bug 3479 - Update manual regarding UTP/STP cable Removed Note from factory reset
02_c	03/14/17	SGG	Warranty Updated